



Planar Waveguide Components

Tunable Optical Dispersion Compensator Modules (TODC) **Preliminary Data Sheet**

ANDevices' TODC product provides a single planar lightwave circuit (PLC) chip solution for multiple-channel or single tunable dispersion compensation for 10 Gb/s and 40 Gb/s long-haul/ultra long-haul and metro systems. The PLC technology based TODC devices provide large dispersion tuning range, fast tuning speed, colorless operation, low cost and compact size. The devices are actuated by electrical power based on thermo-optics. Firmware and electronic control circuit design are available upon request.

Features

- Up to +/- 2100 ps/nm dispersion tuning
- Unlimited colorless devices, entire C-, L- and S-bands coverage
- Fast turning speed (~ msec)
- Low tuning power
- Low PDL and PMD
- Can be integrated with other PLC devices
- Compact size, easily integrated onto line cards
- Highly reliable with no moving part
- No hermetic packaging, Mass producible
- No need for circulator for PLC-TODC T type
- Low cost

Applications

- Multi-channel compensation for LH/ULH, Metro DWDM, submarine
- RX single channel compensation
- Pre- & post compensation
- In-line amplification
- CATV

Options

- Customized design on dispersion and bandwidth
- Standard ITU or custom frequency grids
- Open- or closed-loops
- RS-232, DRAM or I²C
- Look-up table for dispersion and transducer voltage at certain increments
- Firmware and electronic control circuit design
- Custom packaging available

**2933 Bayview Drive
Fremont, CA 94538
Tel: 510-226-8900
Fax: 510-226-8333**

Sales@ANDevices.com

Specifications

Parameters	10 Gb/s (PLC-TODC-10G-R-001)	10 Gb/s (PLC-TODC-10G-T-001)	40 Gb/s (PLC-TODC-40G-R-001)	Unit	Conditions
Center Wavelength	C-, L-, S-bands			nm	Single or multi-channel WDM applications
Channel Spacing ⁽¹⁾	100 or 50		100	GHz	
Insertion Loss	≤ 5.5			dB	Fiber-to-fiber, not including connector and circulator
Insertion Loss variation	≤ 0.3			dB	Across entire band
Channel Loss Passband-Width (1 dB below peak) ⁽²⁾	≥ 11	≥ 7	≥ 33	GHz	At max dispersion setting (the worst case)
	≥ 50 @60% of max dispersion setting	≥ 50 @ 85% of max dispersion setting	\	GHz	At certain percentage of the max dispersion setting
	Infinite for less than 50% of max dispersion setting	Infinite for less than 85% of max dispersion setting	\	GHz	At certain percentage of the max dispersion setting
Dispersion Bandwidth for Group-Delay Ripple	≥ 17	≥ 14	≥ 51	GHz	At max dispersion setting (the worst case)
	≥ 19	≥ 16	\	GHz	At 60% of the max dispersion setting
	≥ 20	≥ 25	\	GHz	At 50% of the max dispersion setting
	≥ 26	≥ 36	\	GHz	At 25% of the max dispersion setting
Group Delay Ripple	≤ 24	≤ 10	≤ 12	ps	Peak-to-peak, in the dispersion bandwidth
Dispersion Tuning Range	-2100 to 2100	-1100 to 1100	-220 to 220	ps/nm	Tunable
Tuning Resolution	20		10	ps/nm	
Tuning speed	10			ms	
Dispersion slope ⁽³⁾	0			ps/nm	
Dispersion Stability	± 20		± 10	pm	due to change of environmental condition and aging across the bands
Wavelength Stability	± 8			pm	due to change of environmental condition and aging across the bands
Polarization Dependent Loss	≤ 0.5			dB	
Polarization Mode Dispersion	≤ 1.0	≤ 1.0	≤ 0.5	ps	
Maximum Optical Input Power	30			dBm	
Device Tuning Power	< 0.5	< 0.5	< 0.5	W	
Power Consumption	< 5	< 5	< 5	W	Incl. TEC controller
Pigtails	1 Used with circulator	2 No circulator needed	1 Used with circulator		
Packaged size	Maximum: 70 mm x 80 mm x 15 mm Fiber pigtail(s) on one side, depending on the module requirement.				Smaller custom packaging available

Note:

(1) 50/200 GHz channel spacings available upon request.

(2) Specification of bandwidth can be customized based on transmission system requirement.

(3) Small dispersion slope compensation will be available in the next run designs.

2933 Bayview Drive
Fremont, CA 94538
Tel: 510-226-8900
Fax: 510-226-8333

Sales@ANDevices.com

Physical and Mechanical Dimensions

This specification will be defined with customer.

TODC Module Interface Connector Definitions

This specification will be defined with customer.

PIN Assignments

This specification will be defined with customer. Below shows a standard example.

Pin #	Function	Symbol	Description
1	Transducer Power Supply	VT	Power supply for transducer
2	Logic Power Supply	VDD	Power supply for logic circuits (+ 5V)
3	Transducer Ground	GndT	Ground Pin for transducer current
4	Logic Ground	GndDD	Ground pin for logic circuit
5-9	Heater Power Supply	VH	Power supply for internal heater
10	Dispersion		Voltage value is related to the dispersion as stored on the EEPROM
11	Temperature Set value	Ts	Temperature setting for the internal heater
12	Heater Power Ground	GndT	Ground pins for the internal heater
13	Serial Clock Input		Serial clock input for the EEPROM
14	Serial Data Input		Serial Data input for the EEPROM
15	Serial Data Output		Serial Data output for the EEPROM

Communication Protocol

Specifications defining all communication protocol, detailing command structure and reporting messages will be determined with customer.

Ordering Information

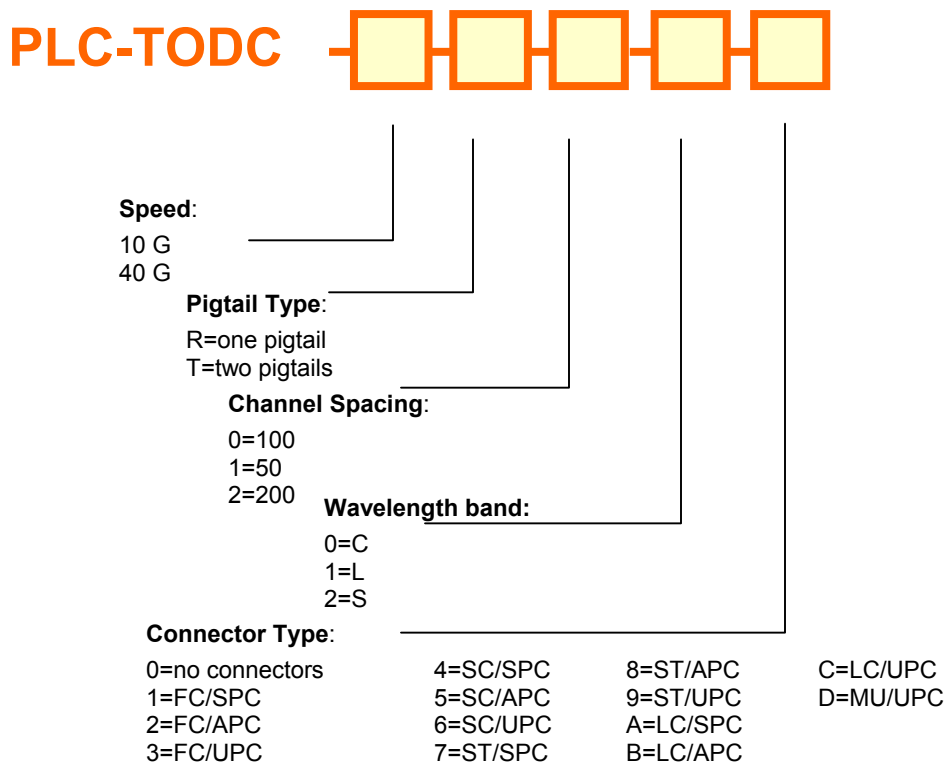

Example: PLC-TODC-10G-R-001: 10 Gb/s, one pigtail type, 100 GHz, C-band, FC/SPC connector

For more information on this product or other products now available from ANDevices, please contact us at sales@andevices.com